

3M-Matic™ 200a Adjustable Case Sealer

Specifications

Box:

Style: Regular slotted container (RSC).
Bursting test: 125 to 275 lbs. per sq. inch single or double wall, B or C flute.

Size:

	Min	Max
Width	6" [150mm]	21.5" [550mm]
Length	6" [150mm]	No limit
Height	4.75" [120mm]	24.5" [625mm]

With masts mounted in upper position

Height	6.5" [165mm]	28.5" [725mm]
--------	--------------	---------------

*3.5" [90mm] with taping heads adjusted to apply 2" [50mm] tape leg lengths and mast stops relocated.

Special modifications may be available for carton sizes not listed above. Contact your 3M sales representative for information.

Note: The 3M-Matic 200a Adjustable Case Sealer can accommodate most boxes within the size range listed above. However, if

Box Length in Direction of Seal is less than .75

Box Height

boxes should be test run to assure proper machine performance.

Tape:

Scotch™ Brand pressure sensitive box sealing tapes.

Width: 1.5 inches or 36mm minimum to 2 inches or 50mm maximum. Roll diameter: up to 16 inches [406mm] diameter on a 3 inch [76.2mm] diameter core.

Machine:

Power: Electrical — 115 V, 60Hz, 1.9A, 220 watts, 8 ft. [2.4m] power cord with grounded plug included.

Contact your 3M sales representative for power requirements not listed above.

Weight:

272 lbs. [123.4kg] uncrated

321 lbs. [145.6kg] crated

Operating rate: Up to 30 cases per minute depending on box length.

Box drive belt speed: 75 fpm [.38 m/s]

Operating conditions: Use in dry, relatively clean environments at 40°F to 120°F [4.4°C to 48.9°C] with clean dry boxes.

Machine should not be washed down or subjected to conditions causing moisture condensation on components.

Equipment Warranty and Limited Remedy: THE FOLLOWING WARRANTIES ARE MADE IN LIEU OF ALL OTHER WARRANTIES, EXPRESS OR IMPLIED, INCLUDING, BUT NOT LIMITED TO, THE IMPLIED WARRANTY OF MERCHANTABILITY, THE IMPLIED WARRANTY OF FITNESS FOR A PARTICULAR PURPOSE AND ANY IMPLIED WARRANTY ARISING OUT OF A COURSE OF DEALING, A CUSTOM OR USAGE OF TRADE:

3M sells its 3M-Matic™ 200a Adjustable Case Sealer with the following warranties:

1. The Taping Head knife blades, springs and rollers will be free from all defects for ninety (90) days after delivery.
2. All other Taping Head parts will be free from all defects for three (3) years after delivery.
3. All other parts will be free from all defects for 2 years after delivery.

If any part is proved to be defective within its warranty period, then the exclusive remedy and 3M's and seller's sole obligation shall be, at 3M's option, to repair or replace the part, provided the defective part is returned immediately to 3M's factory or an authorized service station designated by 3M. A part will be presumed to have

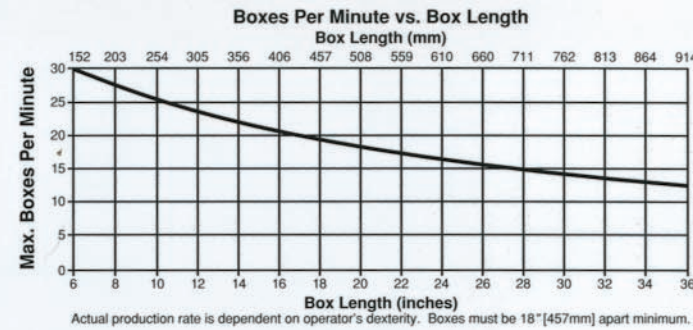

Footprint:

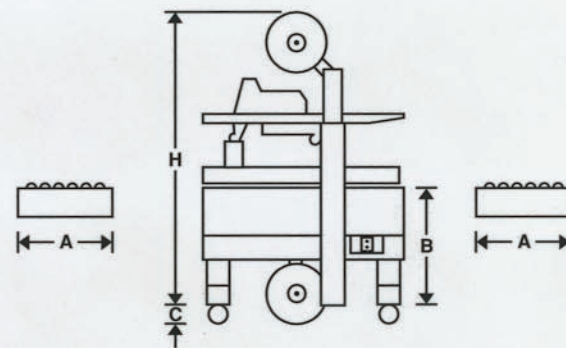
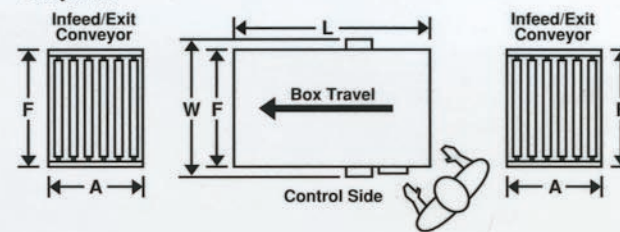

	W	L	H	A*	B	C**	F
Min inches [mm]	31 [787]	36.5 [927]	53 [1346]	18 [457]	24 [610]	4 [102]	24.5 [622]
Max inches [mm]	31 [787]	36.5 [927]	86 [2184]	18 [457]	35 [889]	4 [102]	24.5 [622]
Masts in upper position			90 [2290]		20.5 [520]		
			max		min		
					31 [787]		
					max		

* Infeed/Exit conveyors are optional
** Casters are optional

become defective after its warranty period unless the part is received or 3M is notified of the problem no later than five (5) calendar days after the warranty period. If 3M is unable to repair or replace the part within a reasonable time, then 3M, at its option, will replace the equipment or refund the purchase price. 3M shall have no obligation to provide or pay for the labor required to install the repaired or replacement part. 3M shall have no obligation to repair or replace (1) those parts failing due to operator misuse, carelessness, or due to any accidental cause other than equipment failure, or (2) parts failing due to non-lubrication, inadequate cleaning, improper operating environment, improper utilities, or operator error.

Limitation of Liability: 3M and seller shall not be liable for direct, indirect, special, incidental or consequential damages based upon breach of warranty, breach of contract, negligence, strict liability or any other legal theory.

The foregoing Equipment Warranty and Limited Remedy and Limitation of Liability may be changed only by a written agreement signed by authorized officers of 3M and seller.

The 3M-Matic™ 200a Adjustable Case Sealer
Dependability by design



Packaging Systems Division

3M Center, Building 220-8W-01
St. Paul, MN 55144-1000



40% Pre-consumer waste paper
10% Post-consumer waste paper

"3M-Matic," "AccuGlide" and "Scotch" are trademarks of 3M.

Printed in U.S.A.
© 3M 1996

70-0707-3332-7 (781)BE

3M Packaging

3M-Matic™ 200a Adjustable Case Sealer

Part of a new generation of case sealers that's shaping the future of packaging

Today, the demand for fast, dependable and cost-efficient case sealing is strong. Tomorrow it will be even stronger. 3M's new generation of case sealers is designed to meet both.

Our case sealing machines are specially designed to be versatile, effective and productive. They're sturdy, compact, easy to install. The new AccuGlide™ II Taping Head and unique alternate outboard tape roll mount represent 3M's commitment to innovation as the industry leader in case sealing systems. And 3M-Matic™ components are available worldwide, just one example of how 3M case sealers are built with the demands of global businesses in mind.

The 3M-Matic™ 200a Adjustable Case Sealer is a durable, dependable way to meet basic case sealing needs. It puts tight, consistent seals on regular slotted containers in one operation — up to 30 cases per minute. The patented AccuGlide II taping head precisely applies a full range of Scotch™ Brand Box Sealing Tapes. Both taping heads can be removed easily for cleaning and maintenance. The 200a features a gearmotor drive for heavy duty performance and quick box height/width adjustment for added versatility.

The 200a has dual masts with twin lead screws for extra stability and to allow for uniform height adjustment. The attractive and functional design saves floor space. Plus, the controls can be relocated to convert from standard left side to right side operation.

Standard features include compression rollers that position each box for precise tape sealing; an upper tape roll bracket attached to the machine for easier tape mounting; friction brake drums to prevent tape overrun and provide more consistent tape application; an easy-to-reach alternate outboard tape roll mount for the lower head; and easy-to-install laced replacement belts. Additional features are available as options.

To find out how dependable the 3M-Matic™ 200a Adjustable Case Sealer really is, see your nearest 3M sales representative or contact your local 3M-Matic distributor.

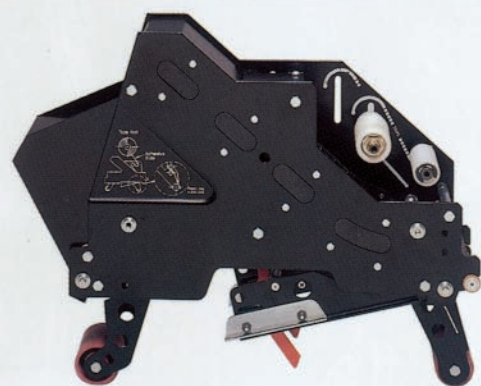

AccuGlide™ II Taping Head

3M's advanced, low impact AccuGlide II taping head with its curvilinear track ensures that even lightweight corrugated cartons are securely and carefully sealed. Provides positive tape starting and precise tape application. The top head floats smoothly and easily to adjust for overpacked boxes. Applies standard 2.75 inch [70mm] tape leg lengths. Can be converted to apply 2.00 inch [51mm] tape leg lengths. And a built-in blade oiler helps prevent adhesive buildup. The head comes with a three year warranty and a 90-day warranty on knife blades, springs and rollers.

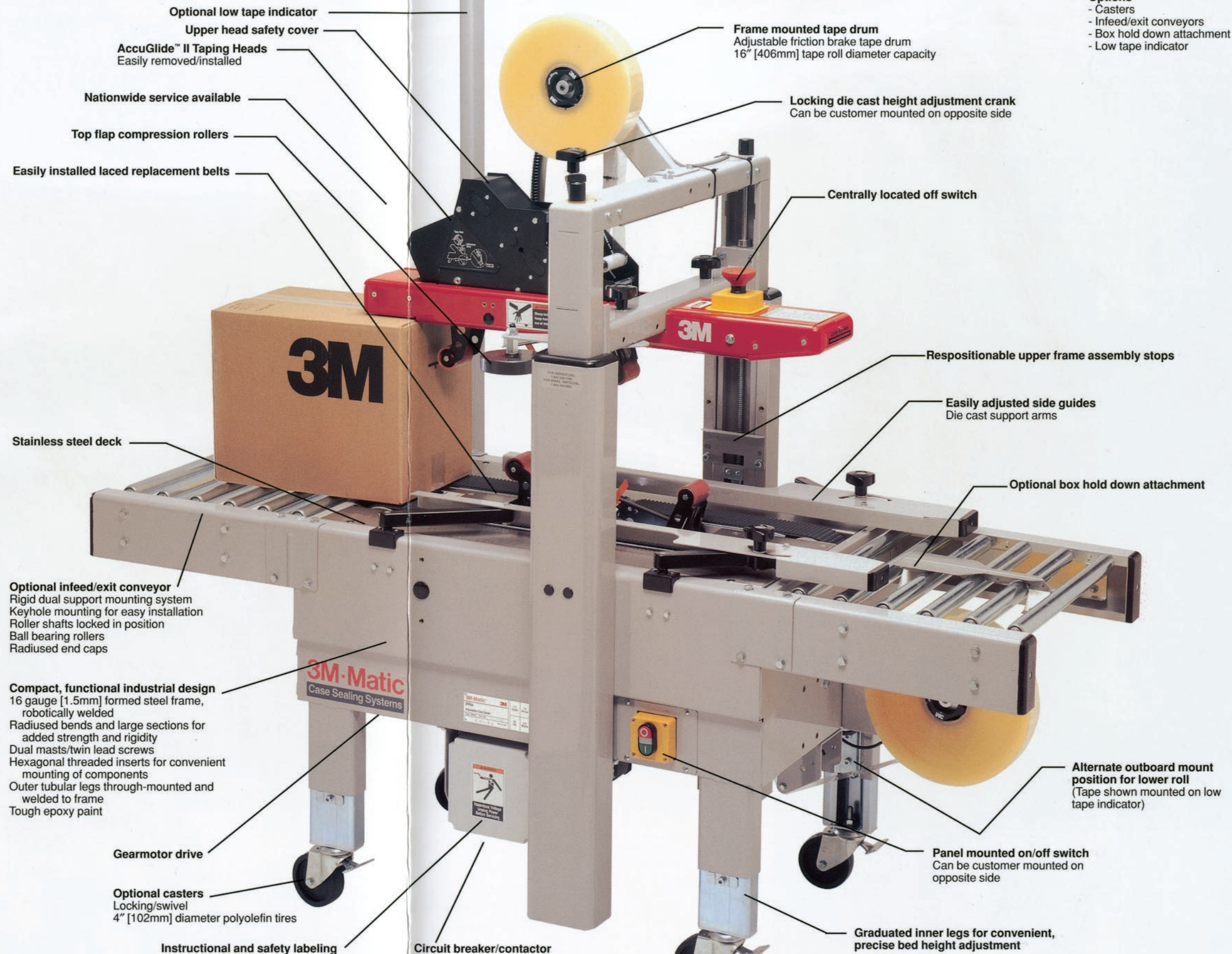

Options

- Casters
- Infeed/exit conveyors
- Box hold down attachment
- Low tape indicator